

VETRALLA II QUARRYCAST FREESTANDING BATH 1650 x 731 X 547

52095.xx

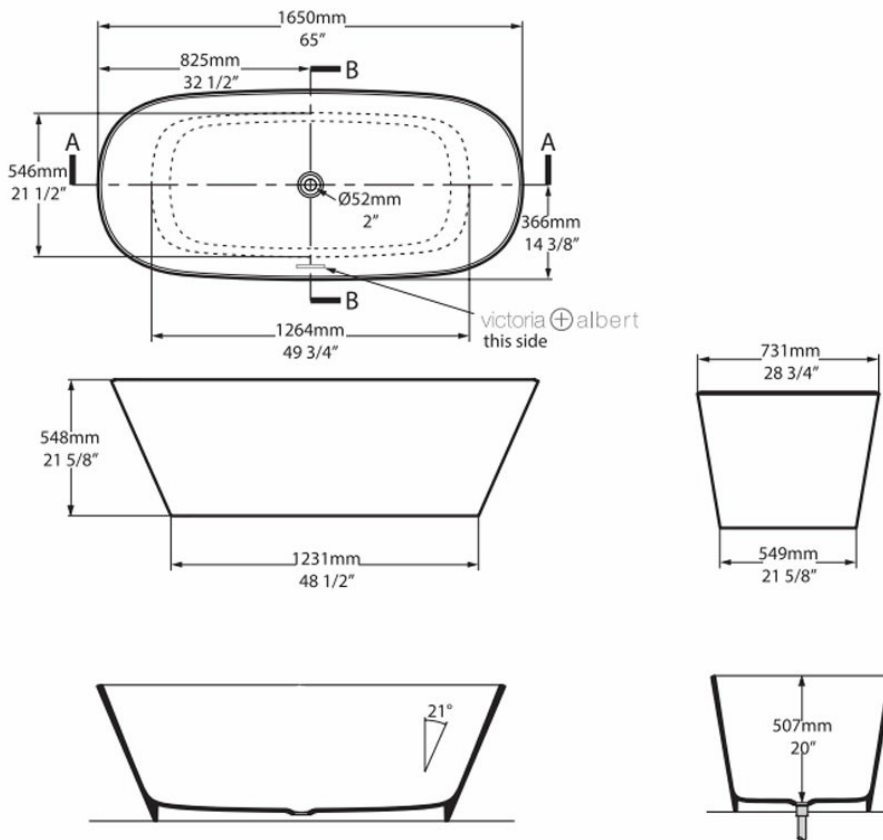

Repairable

Light scratches in the QUARRYCAST material can be repaired and re-polished.



Commercial Use

Suitable for commercial use.



Guarantee

25 Year Guarantee



Exterior Painting

Exterior can be painted or personalised.



Outdoor Use

Can be installed inside or outdoors.



Quarrycast

QUARRYCAST® material is made from a finely ground volcanic limestone and resin mix. 100% one piece, hand finished and packed with naturally desirable properties.



Weight

64KG



Made in South Africa



British owned and operated



Simple, deep and double-ended – ideal for modern bathrooms where space is at a premium. Also offered in a larger format called Vetralla 2. Available in 2 sizes