

Split System Heat Pump Water Heater

HP300S2-F7 (This kit contains the models: THP300S2 & EHP50 S2-F7)



Features

Inverter heat pump technology

Uses 64% to 68% less electricity compared to a standard electric storage water heater

High heat input

1.19kW inverter compressor, providing 4-5kW of heating input

Low GWP refrigerant

Uses R32 refrigerant, which has a GWP factor of 675

SmarterHQ connectivity

The SmarterHQ app allows you to check temperatures and change user modes

Durable inner tank

Durable vitreous enamelled steel inner tank and three magnesium anode

Quiet operation

Operating sound power level of 52dB at a distance of 1 meter

90003373B- The models shown in this Specification Guide (SG) may not be available in all markets and are subject to change at any time. Product specifications may vary from those shown. This SG should not be used as installation guidance for any product. Further information is required to safely and correctly install the products featured here. Specific installation guidance will be available with the product on delivery and on our website haierhome.com

Split System Heat Pump Water Heater

THP300S2-F7

Model	THP300S2-F7
Total water capacity	276L
PTR valve setting	700kPa
Hot & cold inlet connections	RP ¾"
PTR connection	RP ¾"
Power input of electric element	2.6kW
Inlet water pressure	100-500kPa
Ambient temperature range	-15~45°C
Dimensions and connections	
Product dimensions	W580xD622xH1694mm

Note

The power supply for the appliance, and the communication cable are connected via the outdoor heat pump unit.

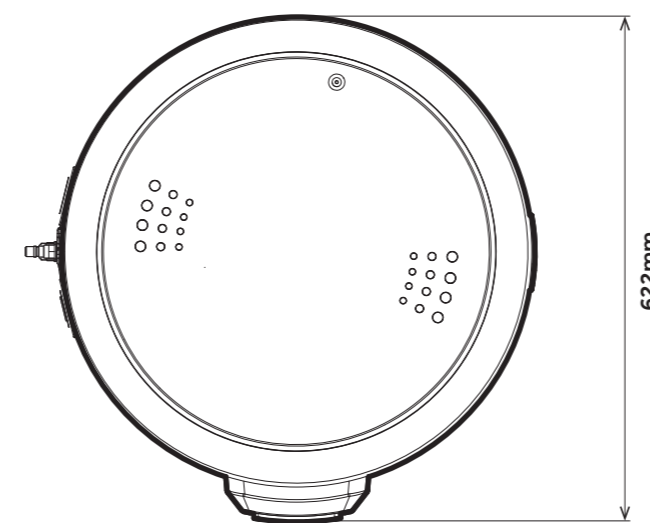

TOP VIEW

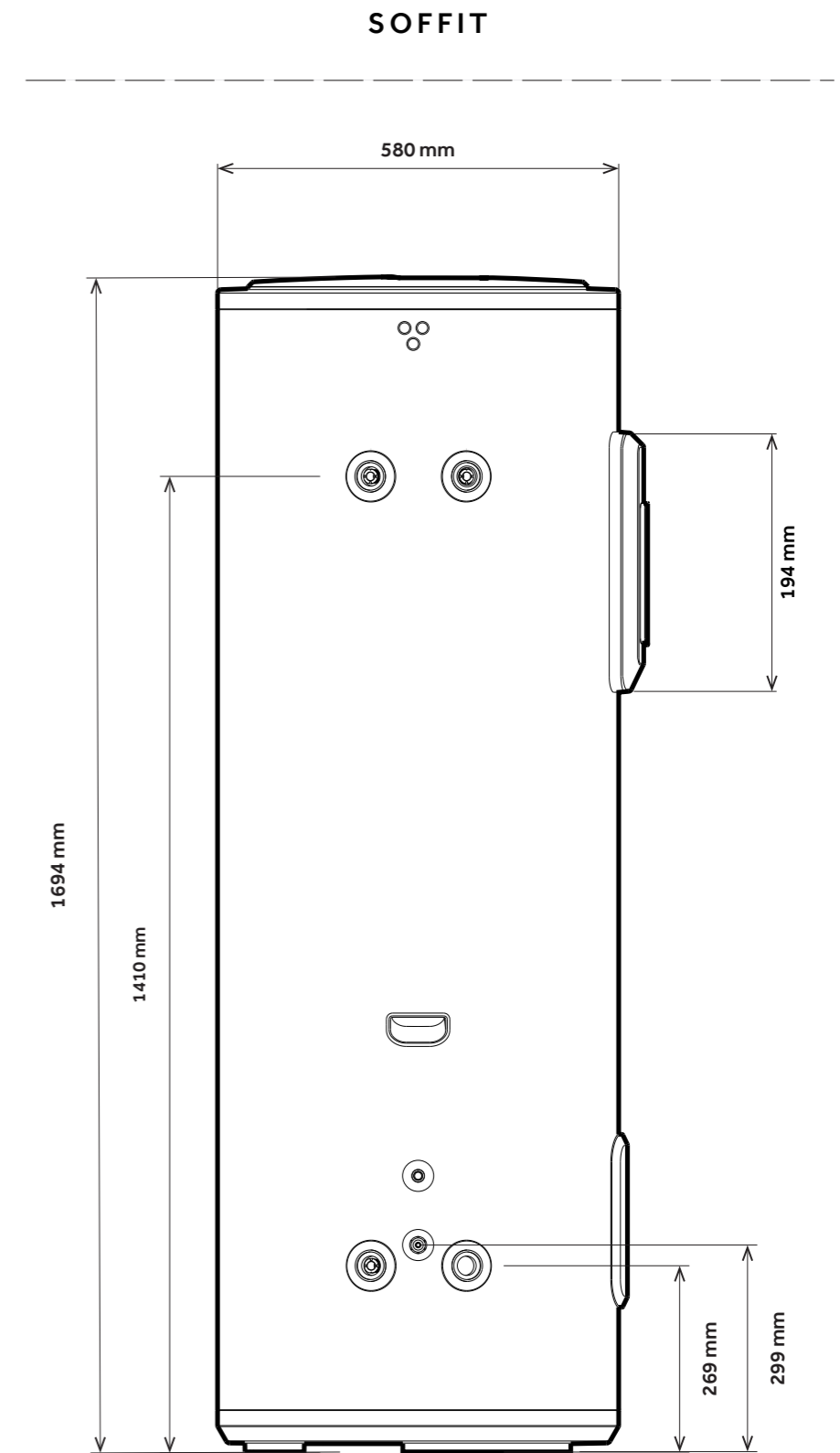

SIDE VIEW

90003373B - The models shown in this Specification Guide (SG) may not be available in all markets and are subject to change at any time. Product specifications may vary from those shown. This SG should not be used as installation guidance for any product. Further information is required to safely and correctly install the products featured here. Specific installation guidance will be available with the product on delivery and on our website haierhome.com

Split System Heat Pump Water Heater

EHP50S2-F7

Model	EHP50S2-F7
Rated power input of the heat pump	1.19kW
Maximum power input of the heat pump	1.7kW
Rated voltage/frequency	220 - 240 V, 50 Hz
Max./Rated power input of the appliance	4.3kW
Max./Rated operation current	20A
COP* _{@ 20°C/15°C}	4.48
Pair coil tube and connection size - Liquid line	1/4" (6.35mm) / (7/16 - 20UNF)
Pair coil tube and connection size - Suction line	3/8" (9.52mm) / (5/8 - 18UNF)
Default temperature setting	55°C
Heating range (with element)	35°C – 75°C
Heating range (heat pump only)	35°C – 55°C
Refrigerant type / weight	R32/0.93kg
Maximum refrigerant pipe length	8m
Sound power level	52dB
Operation temperature range	-15~45°C
Recovery time (@ 19°C air temp, 15°C water temp)	2.5 hours
Recovery time (@ 2°C air temp, 8°C water temp)	4.4 hours
Dimensions and connections	
Product dimensions	W780xD286xH545mm
Product weight	30kg
Packaged weight	33kg

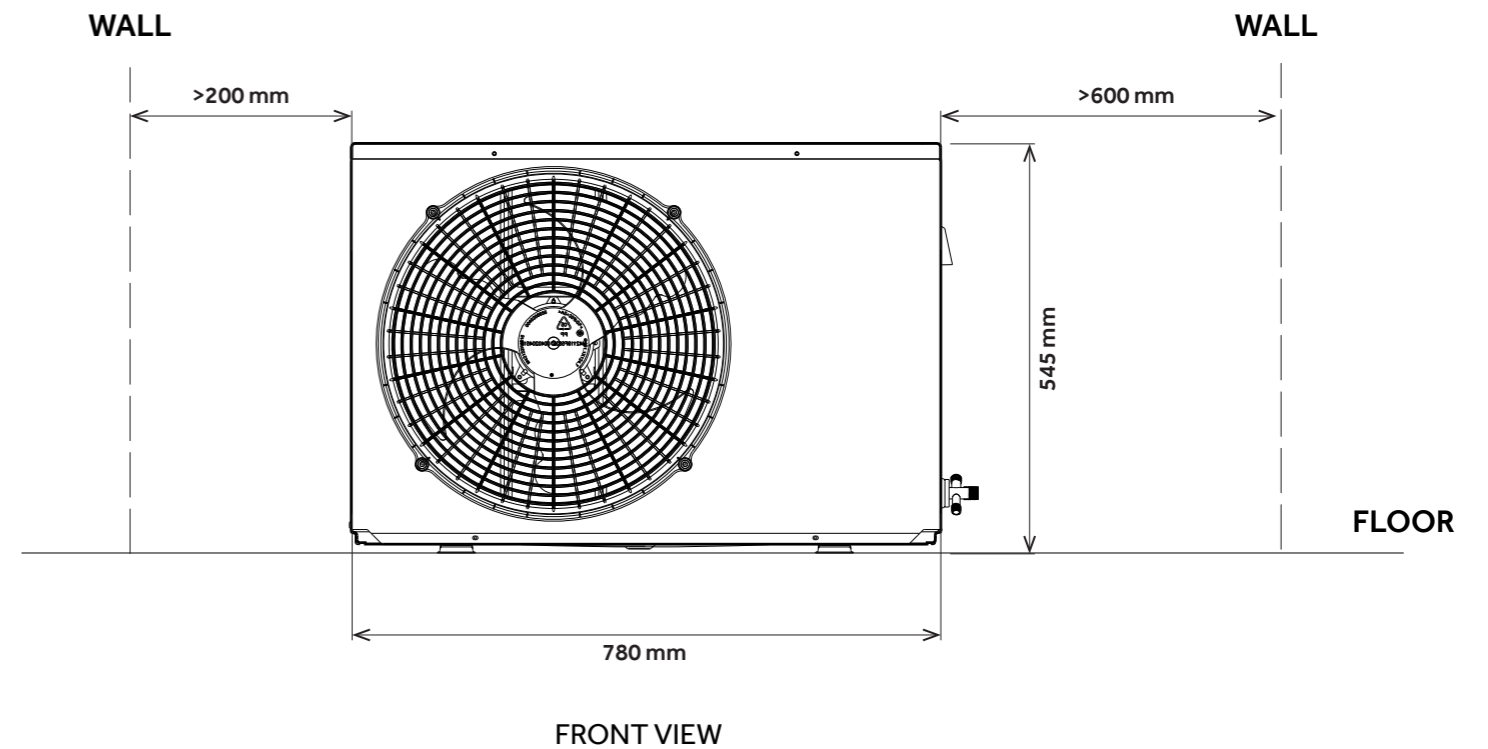
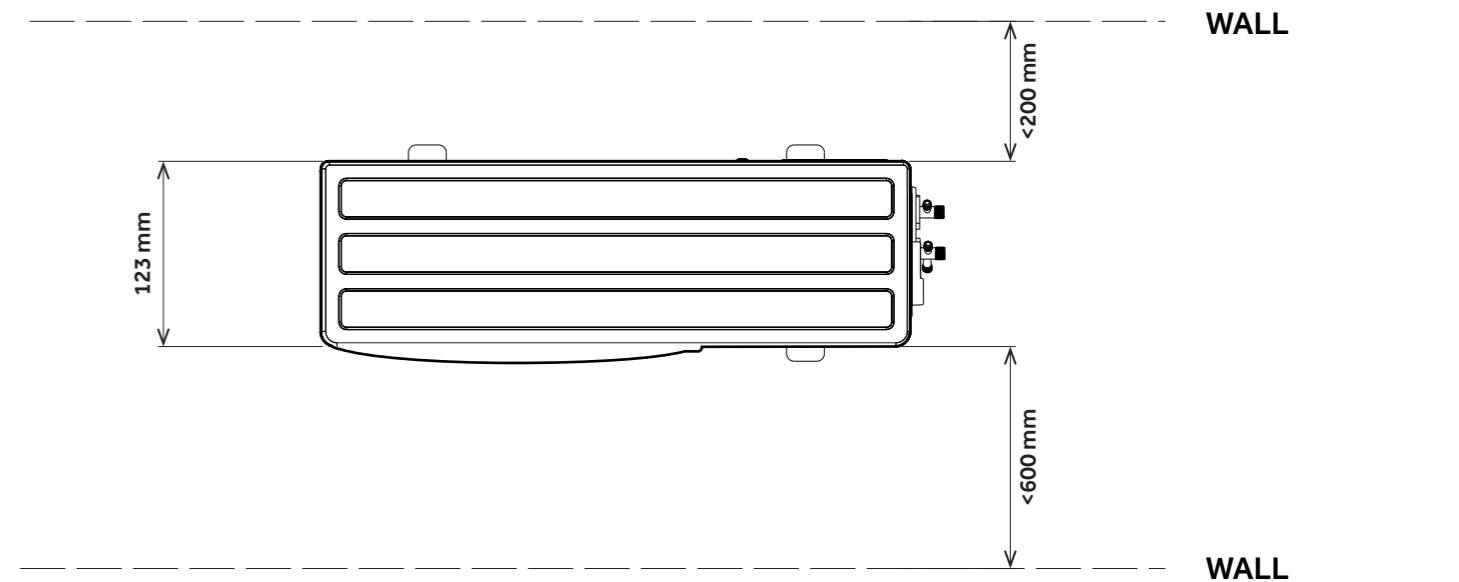

90003373B - The models shown in this Specification Guide (SG) may not be available in all markets and are subject to change at any time. Product specifications may vary from those shown. This SG should not be used as installation guidance for any product. Further information is required to safely and correctly install the products featured here. Specific installation guidance will be available with the product on delivery and on our website haierhome.com